

Accessibility and Accommodation Requests

For questions about accessibility or accommodations for persons with disabilities, or to request a translator, interpreter, or other communication aids, please contact Melissa Bisset at 503-856-3412 or bissetm@keizeror.gov. The City of Keizer is committed to providing equal access to all public meetings and information per the requirements of the ADA and Oregon Revised Statutes (ORS). The Keizer Civic Center is wheelchair accessible.

AGENDA
KEIZER CITY COUNCIL
WORK SESSION

Monday, October 27, 2025
6:00 PM

Robert L. Simon Council Chambers
930 Chemawa Road NE
Keizer, Oregon

1. **CALL TO ORDER**
2. **ROLL CALL**
3. **DISCUSSION**
 - a. **Sidewalk Gap and Repair Program**
4. **ADJOURNMENT**

City of Keizer Mission Statement

Keep City Government Costs And Services To A Minimum By Providing City Services To The Community In A Coordinated, Efficient, And Least Cost Fashion

“Agenda Management Services are being supported, in whole or in part, by federal award number 21.019 awarded to City of Keizer by the U.S. Department of the Treasury.”



City of Keizer Sidewalk Gap and Repair Program

October 27, 2025

Program Purpose



- ◆ Improve pedestrian safety and connectivity
- ◆ If applications exceed funding, prioritize routes used by schoolchildren
- ◆ Offer financial assistance for sidewalk installation and repair



Program Goals



- ◆ Improve Connectivity
- ◆ Fill gaps where sidewalk does not currently exist
- ◆ Assist homeowners who need assistance maintaining their sidewalk.

Sidewalk Infill



Add sidewalks where none exist

◆ Design:

- ◆ Flexible sidewalk types
- ◆ Address water flow, continuity, and neighborhood impact

◆ If Prioritization is needed:

- ◆ ROW availability
- ◆ Near schools
- ◆ Traffic safety data



Sidewalk Repair



- ◆ **Definition:** Fix damaged sidewalks
- ◆ **Responsibility:** Property owners
- ◆ **City Support:**
 - ◆ Short-term financing/loans
 - ◆ Liens available
 - ◆ Tree coordination and replacement



Implementation Strategy



Phase 1: Proof of Concept

- ◆ Use \$100,000 from Street Fund (Keizer Station Area B land sale)

Data Collection:

- ◆ Understand sidewalk section designs

Online Mapping Tool:

- ◆ Show sidewalk on Geographic Information System (GIS)
- ◆ Show ROW status
- ◆ Help residents check eligibility

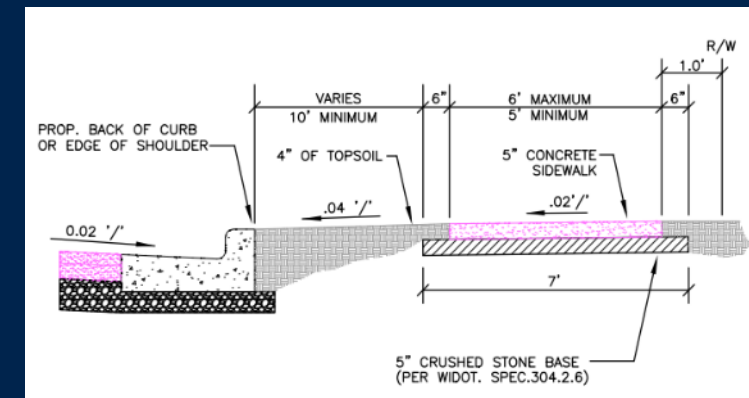
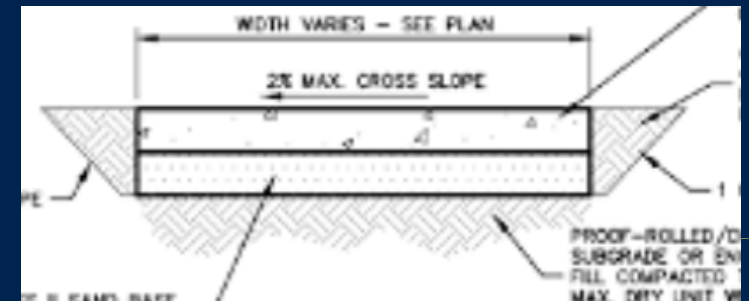

Financing Options



◆ Infill Match:

- ◆ 50% match program
- ◆ 60% match for arterial and collectors
- ◆ New construction does not qualify

◆ Repair Loans:

- ◆ 0% interest for 6 month
- ◆ 5% interest after
- ◆ Option for lien



This Photo by Unknown Author is licensed under [CC BY-NC](#)

Community Engagement



- ◆ Educate residents on responsibilities
- ◆ Publicize program
 - ◆ To renters and homeowners

Application



City of Keizer
Sidewalk Gap Infill and Repair Program Application
Improving pedestrian safety and neighborhood connectivity



Applicant Information

Field	Response
Full Name	
Property Address	
Mailing Address (if different)	
Phone Number	
Email Address	
Are you the property owner?	<input type="checkbox"/> Yes <input type="checkbox"/> No
If no, please provide owner's name and contact info:	

Program Type (Check One)

- Sidewalk Infill (New sidewalk where none exists)
- Sidewalk Repair (Fixing damaged sidewalk)

Eligibility Information

Question	Response
Is the property located in Keizer?	<input type="checkbox"/> Yes <input type="checkbox"/> No
Is the sidewalk near a school or school route?	<input type="checkbox"/> Yes <input type="checkbox"/> No
Does the City have right-of-way where sidewalk is proposed?	<input type="checkbox"/> Yes <input type="checkbox"/> No <input type="checkbox"/> Not Sure
Do you need financing assistance?	<input type="checkbox"/> Yes <input type="checkbox"/> No

Project Details

Please describe the sidewalk issue or location needing improvement:

City of Keizer

Sidewalk Gap Infill & Repair Program

Do you know if the City has right-of-way (ROW) at this location?
 Yes No Not Sure

Required Attachments

Please include the following with your application:

- A photo of the location (optional but helpful)
- A simple sketch or map of the area (if available)
- Proof of ownership or permission from the property owner (if applicable)

Acknowledgment

I understand that submission of this application does not guarantee approval and that the City of Keizer will evaluate eligibility, location, and funding availability.

Signature: _____ **Date:** _____

For staff use only below this line

Field	Response
Is Property in City	<input type="checkbox"/> Yes <input type="checkbox"/> No
Does the City have right-of-way Where sidewalk is proposed?	<input type="checkbox"/> Yes <input type="checkbox"/> No
Which street section is approved?	
What is expected cost?	\$
Is ownership or tenancy established?	<input type="checkbox"/> Yes <input type="checkbox"/> No
	<input type="checkbox"/> Yes <input type="checkbox"/> No
Staff Approval	<input type="checkbox"/> Yes <input type="checkbox"/> No

Staff Signature: _____ **Date:** _____



Approval Process

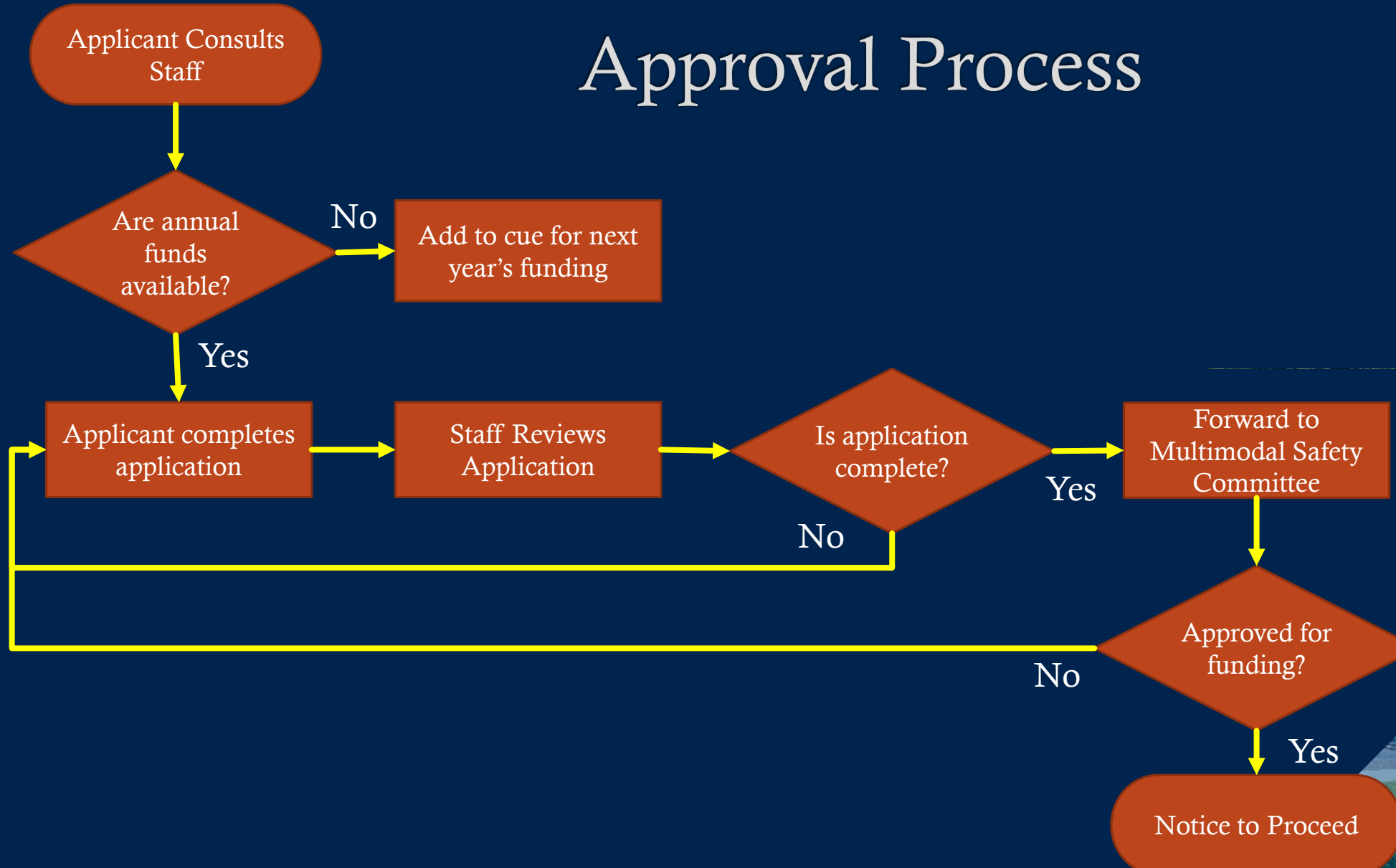



Construction Process

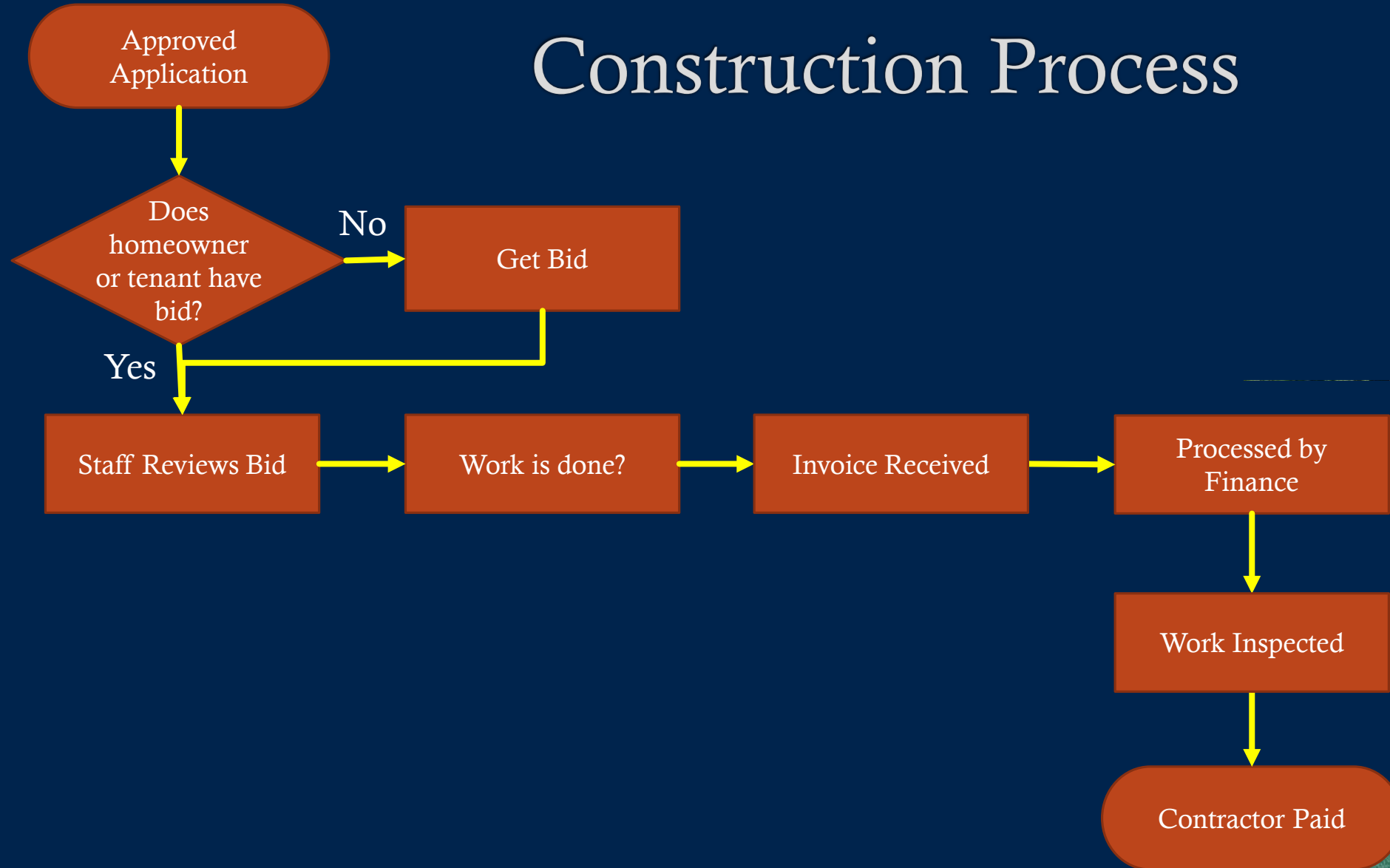

Next Steps



◆ **3-Month Goal:**

- ◆ Finalize draft
- ◆ Present to Multimodal Safety Committee
- ◆ Present program to council for approval
- ◆ Acquire initial funding

◆ **Ongoing:**

- ◆ Launch Monitor and adjust

Questions and Feedback



Let's discuss priorities, concerns, and next steps.